

DR-17E
NET WEIGHT: 6.58KG (with Stand)
5.82KG (w/o Stand)

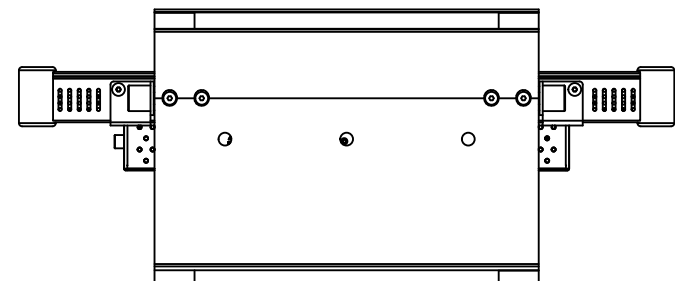
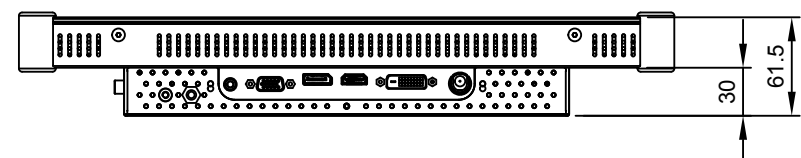
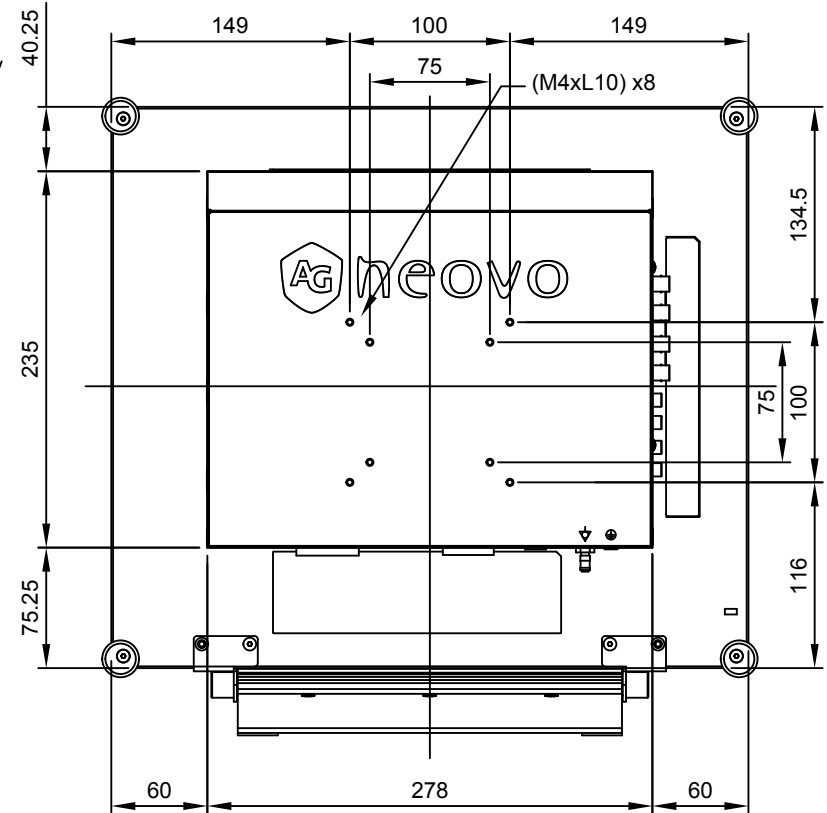
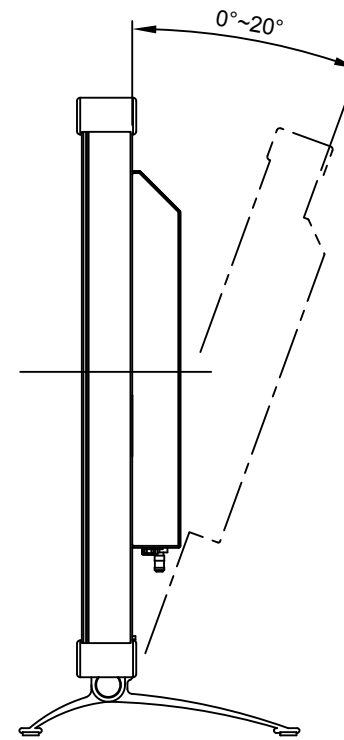
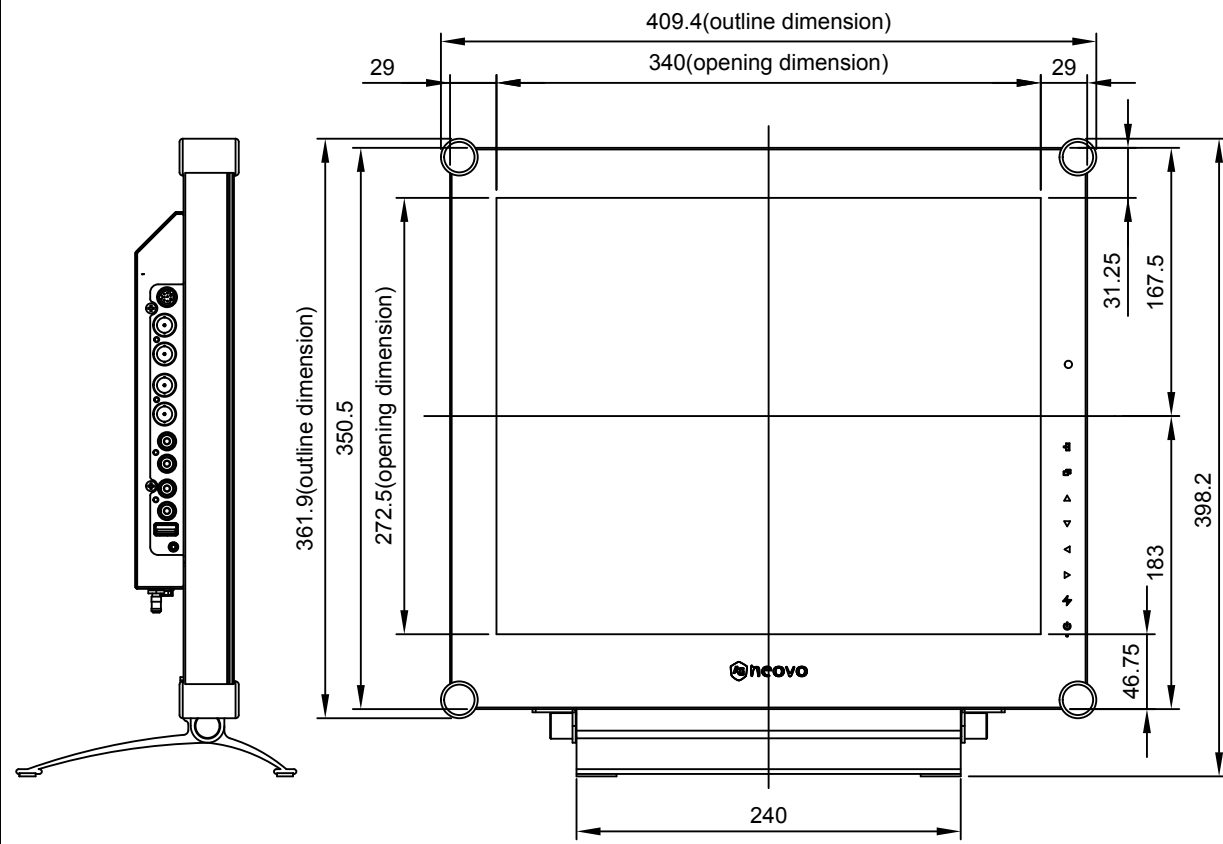

SPECIFICATIONS SUBJECT TO CHANGE WITHOUT NOTICE.

 www.agneovo.com	Model Name:
	DR-17E
<small>THIS DRAWING ON THIS PRINT AND INFORMATION BELONG WITH AG Neovo. ANY REPRODUCTION IN PART OR WHOLE WITHOUT WRITTEN PERMISSION OF AG Neovo IS PROHIBITED.</small>	<small>THIRD ANGLE PROJECTION</small>
SCALE 1:1	UNITS MM V.01